

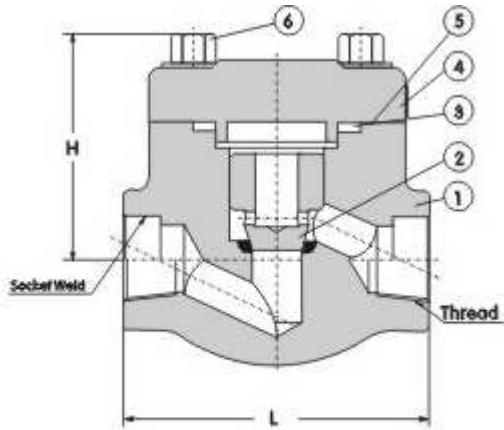

PISTON CHECK VALVE 900LB~1500LB

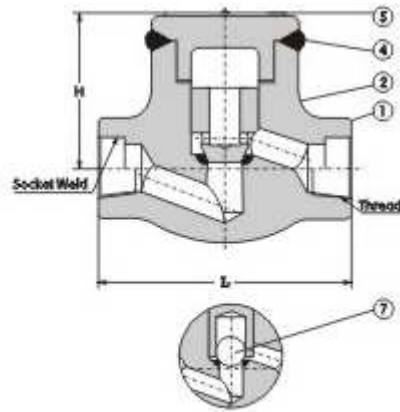

Eg.FIG.C9C4Y



Eg.FIG.WC9C4Y

Features:

Piston Check Valve 900Lb~1500Lb

Standard Material Specifications

NO.	Part Name	CS to ASTM	AS to ASTM	SS to ASTM	
		Type A105	Type F22	Type F304(L)	Type F316(L)
1	Body	A105	A182 F22	A182 F304(L)	A182 F316(L)
2	Piston Disc	A276 420	A276 304	A276 304(L)	A276 316(L)
3	Gasket	Corrugated SS + graphite		SS + PTFE	
4	Bonnet	A105	A182 F22	A182 F304 L	A182 F316(L)
5	Nameplate	SS			
6	Bolt	A193 B7	A193 B16	A193 B8M	A193 B8M
7	Ball	A182 F304	A182 F304	A182 F304	A182 F304
Suitable Medium		W.O.G.etc	W.O.G.etc	HNO ₃ ,CH ₃ OOH etc	
Suitable Temperature		-29~425	-29~550	-29~180	

Note: Other materials are available upon request.

Dimensions (mm) and Weights (Kg)



NPS	Conv.	3/8"	1/2"	3/4"	1"	1-1/4"	1-1/2"	2"	
	Full		3/8"	1/2"	3/4"	1"	1-1/4"	1-1/2"	2"
L		92	111	111	120	152	172	200	220
H		65	79	79	97	104	120	139	215
Weights	Bolted	1.6	3.4	3.3	5.5	6.0	9.2	12.9	16.2
	Welded	1.3	3.2	3.1	4.8	5.4	8.5	11.2	14.3